

SERIES:

MGDU2



3003 9th Avenue SW
 PO Box 50
 Watertown, SD 57201
 Toll free: 888-978-2638
 Ph: 605-886-3326
 Fax: 605-886-8995



Low Profile, High Current Power Inductors

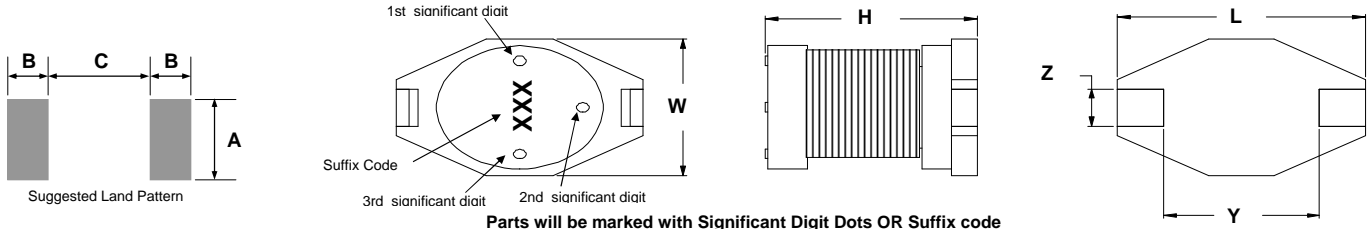

Series Number	Maximum Dimensions			Reference Dimensions					
	Units	L	W	H	Y	Z	A	B	C
MGDU2	inches	0.510"	0.370"	0.130"	0.300"	0.100"	0.110"	0.115"	0.290"
	[mm]	[12.95]	[9.40]	[3.30]	[7.62]	[2.54]	[2.79]	[2.92]	[7.37]

Features:

- High energy storage and low resistance
- Ideal for DC-DC step-up or step-down conversion.
- Reliable surface mounting, flat top for pick and place mounting
- Robust temperature deflection to prevent damage during solder reflow.
- Operating Temperature -40°C to +85°C.



Terminal Plating is Gold Flash over Ni
 260°C Maximum reflow temperature per J-STD020

Notes:

- Inductance measured at 100kHz, 100mVrms at 20°C.
- DCR (DC resistance) are maximum @ 20°C.
- Irms is the current applied to produce a typical 30°C temperature rise from nominal inductance.
- Isat is a maximum applied AC + DC current.
- Isat is the current applied to produce a typical 10% drop in nominal inductance
- Tolerance suffix of M = ±20%.

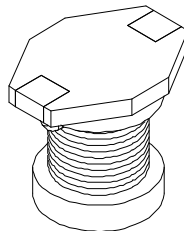
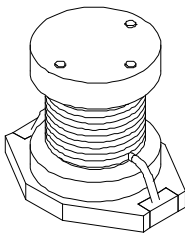
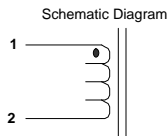

Contact CoEv for additional inductance values

Lead Free Part Number	L μH	MGDU2			Tolerance Suffix
		DCR W	Isat A	Irms A	
	1.0				
	1.5				
	2.2				
	3.3				
	4.7				
	5.6				
	6.8				
	8.0				
MGDU2-00001	10	0.110	2.40	2.00	M
MGDU2-00002	15	0.150	2.00	1.50	M
MGDU2-00003	22	0.230	1.60	1.30	M
MGDU2-00004	33	0.300	1.40	1.10	M
MGDU2-00005	47	0.390	1.00	0.80	M
MGDU2-00006	68	0.660	0.90	0.70	M
MGDU2-00007	100	0.840	0.70	0.60	M
MGDU2-00008	150	1.200	0.60	0.50	M
MGDU2-00009	220	1.900	0.50	0.40	M
MGDU2-00010	330	2.700	0.40	0.30	M
MGDU2-00011	470	4.000	0.30	0.20	M
MGDU2-00012	680	5.300	0.20	0.10	M
MGDU2-00013	1000	8.400	0.10	0.05	M

Specifications subject to change

Call Toll Free: 888-978-2638 Website: www.tycopowercomponents.com

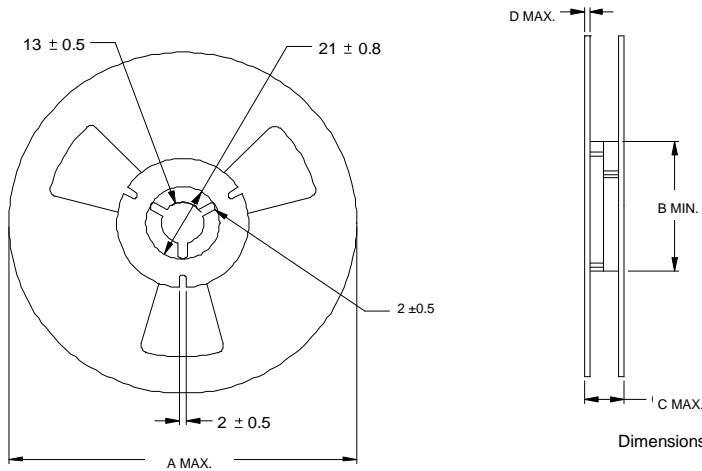

Dimensions are in millimeters unless specified.

Series Number	Reel dimensions				Reel Qty	Carton (Box) Qty.	Packaging Specification
	Units	A	B	C			
MGDU2	in.	14.17"	3.94"	0.88"	1000	5000	90-0058
	[mm]	[360]	[100.0]	[22.4]			

PACKAGING NOTE: Only pressure sensitive cover tape is to be used.

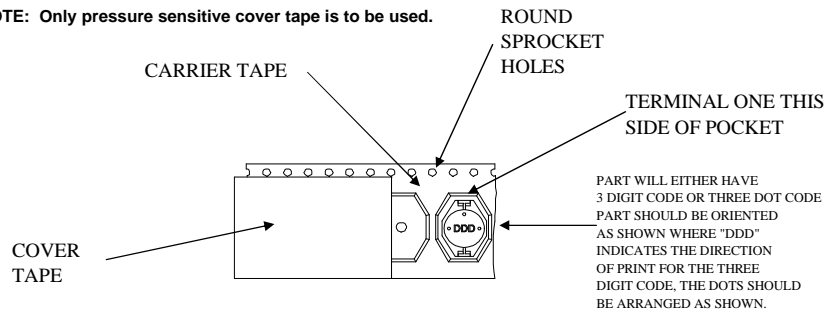
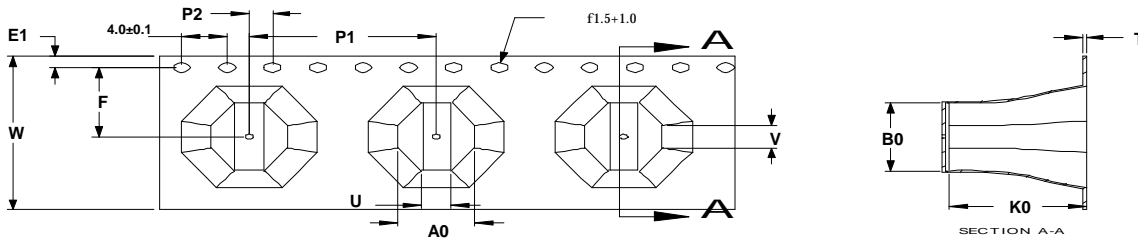

FIGURE 1
CARRIER TAPE AND PART



Series	A0 ± 0.1	U ± 0.1	V ± 0.1	P1 ± 0.1	P2 ± 0.1	W ± 0.3	F ± 0.1	E1 MIN.	B0 ± 0.1	K0 ± 0.05	T ± 0.05
MGDU2	9.50	3.90	4.00	12.00	2.00	24.00	11.50	1.75	13.10	3.10	0.35

RoHS Compliant

Customer Packaging Specifications
For Print Distribution to Customers

Series	Revision
MGDU2	A0

Item	Specification	Test Method/Condition
Environmental		
Static Humidity	After exposure part remains within specified electrical parameters for L, Q and DCR.	Expose parts to an environment of +50°C with 90 to 95% R.H. for 100 hours. After exposure, allow parts to dry for 2 hours before measurements are taken.
Storage Life	After exposure part remains within specified electrical parameters for L, Q and DCR.	Subject parts to an environment of +50°C 90 to 100% R.H. for 46 to 50 hours. After exposure, allow parts to dry for 2 hours before measurements are taken.
Moisture Resistance	After exposure, part shall not have a shorted or open winding.	Per MIL-STD 202 Method 106, ten 24 hour cycles at +25°C to +65°C at 80 to 95% R.H. During any of the first 9 cycles, inductors are revolved from the chamber and exposed to -10°C for 3 hours. Allow parts to dry for 2 hours before measurements are taken.
Temperature Cycle	After exposure part remains within specified electrical parameters for L, Q and DCR.	10 cycles (Air to Air) 1 cycle shall consist of: 30 minutes exposure to +85°C 30 minutes exposure to -40°C Allow 20 minutes transition between extremes.
Temperature Shock	After exposure part remains within specified electrical parameters for L, Q and DCR.	10 cycles (Air to Air) 1 cycle shall consist of: 30 minutes exposure to -45°C 30 minutes exposure to +125°C 15 seconds maximum transition between temperatures
General		
Storage Temperature Range	-40°C to +85°C	
Operating Temperature Range	-40°C to +85°C	
Flammability	IEC 695-2-2	Withstands needle-flame test
Other		
Vibration	After exposure part remains within specified electrical parameters for L, Q and DCR.	Inductors shall be randomly vibrated per NAVMAT P9492 profile. Samples shall be subjected to 0.04G/Hz for a minimum of 15 minutes per axis, for each of the three axes.
Mechanical Shock	After exposure part remains within specified electrical parameters for L, Q and DCR.	Test per MIL-STD 202 method 213 test condition A, test mounted samples 3 axes, 6 times, totaling 18 shocks. (50Gs, 11ms, half-sine).
Solderability	Wetting shall cover 90% minimum of each termination	Dip pads in RMA flux, 63/37 solder (Sn/Pb) at 232°C for 5 seconds ±2 seconds.
Component Adhesion (Push Test)	4 pounds	Apply and measure force with a digital force gauge set.
Resistance to Solvent	No sign of degradation in appearance or marking detail.	Withstands 6 minutes of alcohol. Withstands 3 minutes forced spray Freon TMS
Load Life	After exposure, part shall not have a shorted or open winding.	Parts to be stored at 110°C for 1000 hours with rated current applied. Parts to be tested at: start, 500 and 1000 hours. Allow 2 hours at room temperature before testing.



RoHS Compliant

For Print Distribution to Customers

Series	Revision
MGDU2	A0
Sheet 3 of 7	